

**INSTALLATION & CLEANING INSTRUCTIONS  
HARLEY-DAVIDSON SPORTSTER  
MODEL'S 212 & S212 1994 thru 1999**

U' Verify that this kit and instructions are for your MAKE/MODEL motorcycle.

**PARTS INVENTORY**

<u>Item</u>	<u>Quantity</u>
3/8" REG HEX SPOOL	2
5/16" X 2 1/4" SOCKET HEAD BOLT	2
5/16" MOUNTING SPOOL	2
5/16" - 18 LOCKNUT	2
22 X 10.4 X 5 MM BLACK PLASTIC SPACER	2
SILICONE	1
<b>TURN SIGNAL RELOCATION KIT includes:</b>	
ELECTRICAL WIRE	48"
WIRE CONNECTOR	4
RELOCATION BRACKET	1
1/4" - 20 X 3/4" HEX CAP SCREW	2
1/4" - FLATWASHER	4
1/4" - 20 LOCKNUT	2
5/16" - 24 X 3/4" HEX CAP SCREW	2
5/16" - FLATWASHER	2
5/16" - LOCKWASHER	2
<b>FOR BULLET LIGHT ADD:</b>	
5/16"- 18 X 3/4" HEX CAP SCREWS	2
8 X 22 X 5MM BLACK PLASTIC SPACERS	2

**TURN SIGNAL RELOCATION**

1. Refer to Figure 1.
2. Remove seat.

U' *SAFETY: DISCONNECT BATTERY PRIOR TO ALL WIRING MODIFICATIONS*

3. Remove turn signals. Observe and mark "left" and "right" for reinstallation.

U' Turn signal bracket may be oriented forward or backward as required.

4. Install turn signal bracket between license plate and license plate bracket using 1/4" - 20 X 3/4" Hex cap screws, 1/4" flat washers, and 1/4-20 locknuts.

Note: For bullet style turn signal light models refer to figure 3, disassemble and discard turn signal extension and insert 8x22x5mm black plastic spacer in place of the extension.

5. Mount turn signals directly to bracket using 5/16" - 24 x 3/4" hex cap screws with 5/16" lock washers and 5/16 flat washers. If original wire was inside stalk, remove plug and reroute wires to outside. For a clean installation remove top center mounting bolt on license plate bracket and run wires through this hole.

U' Information: Not all license plate mounts are grounded. In some cases, it may be necessary to run a ground wire to turn signal bracket.

U' WARNING: States may have minimum width requirements on motorcycle turn signals, so check your local laws.

6. Turn signal wires must be extended. We recommend splicing inside turn signal housing. Splice wires, one at a time, while observing color-code.

7. Connect battery and test turn signals for function.

### SADDLEBAG INSTALLATION

8. Refer to Figure 2.

9. Remove rear fender mounting bolts on each side and replace original bolts with the (two) 5/16" x 2 1/4" socket head bolts and 5/16" mounting spools with chamfer on spool under head of Allen bolt. Install 5/16 - 18 locknuts on inside of fender. Verify that adequate clearance exists between the end of the bolts and tire.

10. Remove upper shock nut and washer replace with 22 x 10.4 x 5mm black plastic spacer and 3/8" hex spool.

11. Repeat procedure on opposite side.

12. Reinstall seat.

U' Information: Bags will be easier to mount and remove if a small amount of silicone lubrication is applied to rubber mounting points.

13. Mount saddlebags over spools on fender strut and secure with clips retained inside bags.

14. Inspect each clip to verify each clip is properly seated in retaining groove. See View "A".

### SADDLEBAG CARE INSTRUCTIONS

- Do not exceed 20 lbs. per saddlebag this includes sitting or standing on bags, it is a common occurrence for a non-rider to attempt to sit on bags, this also may void warranty.
- Periodically, apply a small amount of silicone lubrication to rubber mounting points. Saddlebags will be easier to mount and remove.
- Remove grease, oil or mud with mild detergent and water. For fast touch-up, *Windex or Turtle Wax Formula 2001*. The use of any other chemicals may discolor the saddlebags.
- Whenever possible, release locks on saddlebag lids to allow the gaskets to expand during storage.
- If you use bags to ice down drinks, later remove bags, drain water and blot up excess water. The foam interior lining is closed-cell foam and does not retain water. Leave lids open until interiors are dry.
- Use white *Scotch Brite* scour pad (ultra-fine, only) to remove scratches & shiny spots and restore luster. This can be purchased at an automotive supply store.
- When locking or unlocking saddlebags, place one hand on top of bag near lock and apply a moderate amount of down pressure while turning the key. This compresses the weather-seal enabling the locking mechanism to turn freely.
- Always inspect to verify each of the saddlebag mounting clips on inside of bag is properly installed when mounting bags. Clips fit into groove on mounting spool. Failure to perform this correctly can cause severe damage and may void warranty.

212 & S212

# TURN SIGNAL RELOCATION

Figure 1

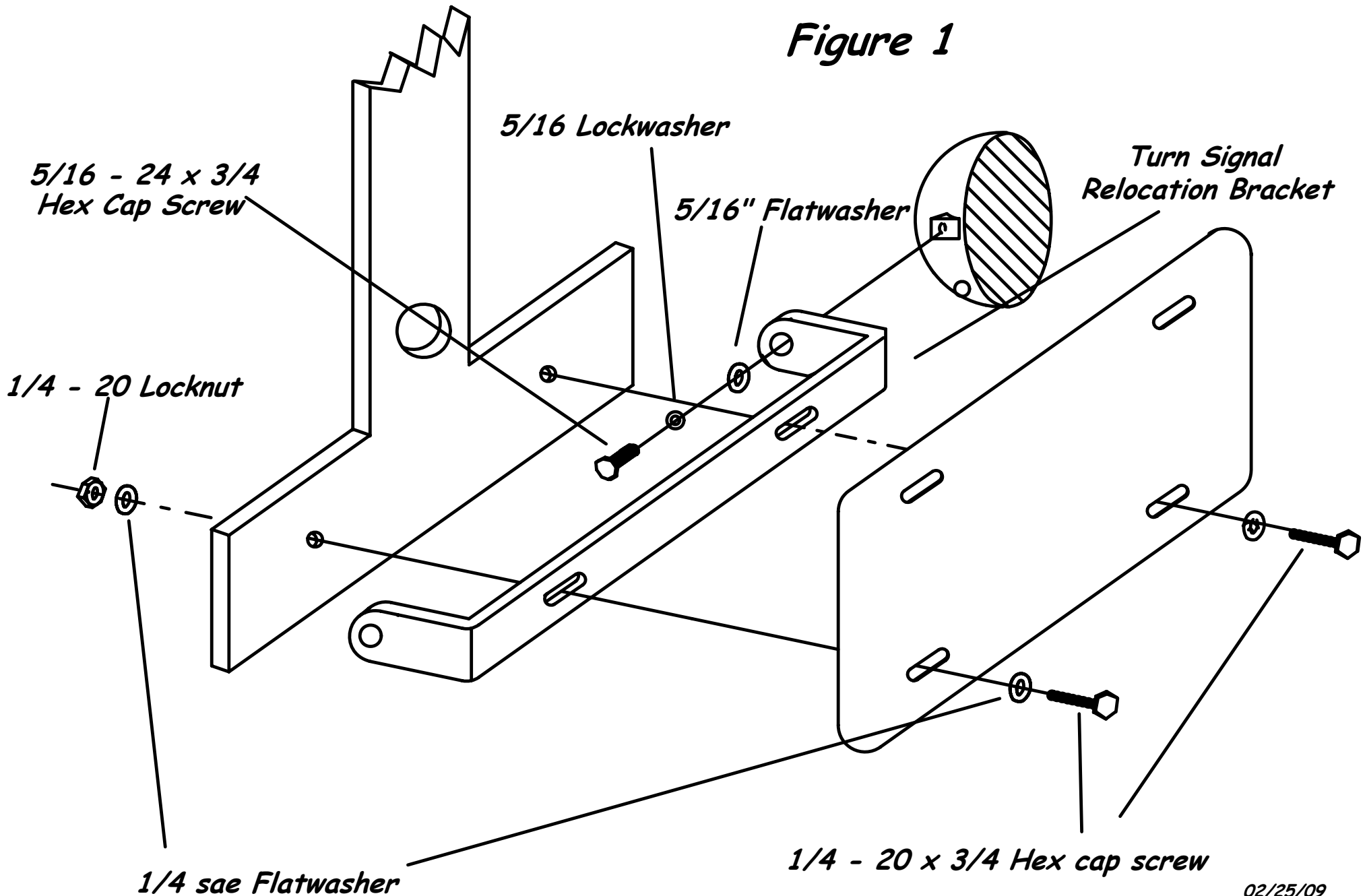

# INSTALLATION INSTRUCTIONS HARLEY-DAVIDSON SPORTSTER MODEL'S 212 & S212 1994 thru 1999

Figure 2

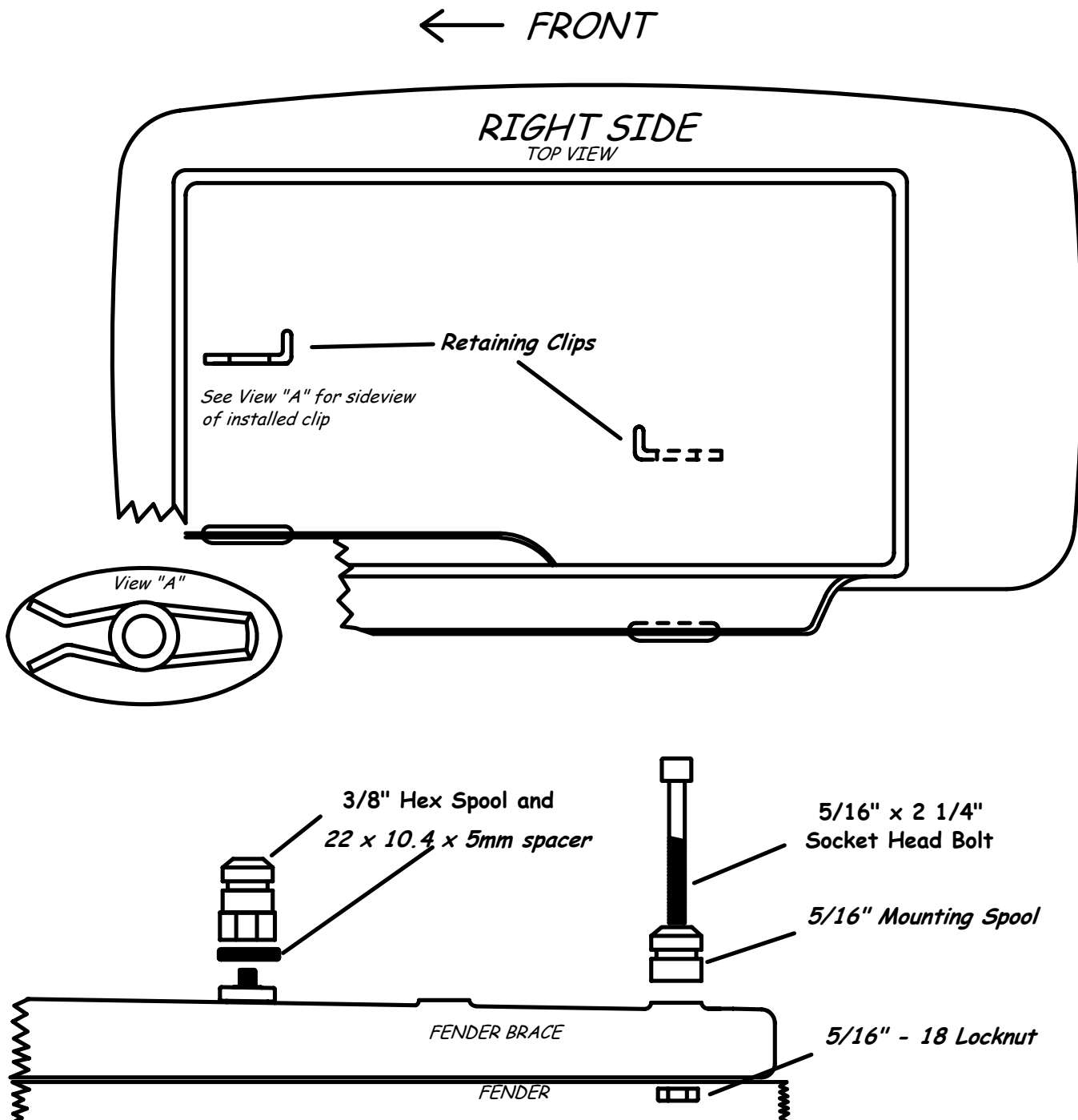

212 & S212

# *For Models With Bullet Style Light Turn Signal Relocation Kit*

*Figure 3*

